



Capacity

- **Tray dimensions:**
 - 400 x 600 mm (46.x models)
 - 400 x 800 mm (48.x models)
- **Number of levels:**
 - 4 (xx.4 models)
 - 9 (xx.9 models)
 - 10 (xx.10 models)

Use

KRYSTAL+ is an electric convection oven that can hold baking trays measuring 400 mm wide and 600 or 800 mm deep and is fitted with 4, 9 or 10 levels. Compact and reliable, **KRYSTAL+** easily fits into small spaces. Its versatility provides perfect baking conditions for a very wide range of bakery products and pastries, including the lightest and most delicate products.

Operating principle

KRYSTAL+ makes it possible to bake all kinds of bakery and pastry products to perfection. The Ventilation Speed Variation function is perfect for the lightest, most delicate products, like macarons, as it offers suitably gentle baking. The Partial Load function enhances usability in the event of reduced production. Numerous accessories are available for the oven's upper and lower sections.

Construction

- Width of 780 mm, identical to the MIZAR rack convection oven
- SENSITIV'2 touchscreen control panel
 - With the Ventilation Speed Variation function
 - With the Partial Load function
- (or) Ergocom electromechanical control panel
- Steam system (depending on the model)
- Ergonomic door handle on the left or right
- Double-glazed glass and infrared treatment
- Fresh air inlet, adjustable via a pull knob under the door
- Motorised steam vent
- Decompression valve
- Standard or reduced power (chosen when placing the order)
- Accessories (upper section)
 - Hood only
 - Hood with extractor
 - Hood with steam condenser
 - Wall-mounted condenser
- Accessories (lower section)
 - Stand: tray storage with a drawer, without castors (H = 850 mm)
 - Stand: tray storage with a drawer and castors (H = 850 mm)
 - Stand: tray storage with a drawer and castors (H = 970 mm)
 - Proofbox without a drawer or castors (H = 850 mm)
 - Proofbox with a drawer and castors (H = 970 mm)
- Possible to stack two 46.4 or 48.4 models

Advantages

- Compact — just 780 mm wide
- Smart, thanks to its SENSITIV'2 touchscreen control panel
- Versatile, with the Ventilation Speed Variation function
- Numerous configuration possibilities

KRYSTAL+ TRAY CONVECTION OVENS

Technical data

	KRYSTAL+ 46.4	KRYSTAL+ 46.9	KRYSTAL+ 46.10	KRYSTAL+ 48.4	KRYSTAL+ 48.9	KRYSTAL+ 48.10
Support						
Tray dimensions (mm)		400 x 600			400 x 800	
Number of levels	4	9	10	4	9	10
Door opening direction						
Handle on the left		•			•	
Handle on the right		o			o	
Type of control						
SENSITIV'2 (with Partial Load and Ventilation Speed Variation)		•			•	
Ergocom		- €			- €	
Steam						
Without steam generator	- €	-	•	-	-	•
With steam generator	•	•	-	•	•	-
Anti-scale filtration kit and/or pressure reduction kit	€	€	-	€	€	-
Accessories (upper section)						
Hood with <u>or</u> without steam extractor fan		€			€	
Hood with steam condenser <u>or</u> Wall-mounted condenser		€			€	
Accessories (lower section)						
Stand: tray storage with a drawer, with <u>or</u> without castors (H = 850 mm)		€			€	
Stand: tray storage with a drawer and castors (H = 970 mm)		€			€	
Proofbox without a drawer or castors (H = 850 mm)		€			€	
Proofbox with a drawer and castors (H = 970 mm)		€			€	
Power supply voltage (oven)						
3N ~ 400 V (standard power)		•			•	
3N ~ 400 V (reduced power)		o			o	
3 ~ 230 V		o			o	
Power supply voltage (extractor and condenser)						
1N ~ 230 V		•			•	
Connection capacity (kW)						
Of the oven (if standard power)	10.3	18.6	18.6	10.3	18.6	18.6
Of the oven (if reduced power)	6.9	12.5	12.5	6.9	12.5	12.5
Dimensions (mm)						
Oven height (A)	530	1055	1055	530	1055	1055
Height of stand / proofbox (B1 or B2)		850 <u>or</u> 970			850 <u>or</u> 970	
Oven depth (C)		1145			1340	
Depth of oven with hood (D)		1465			1660	
Depth of oven, door open (E)		1700			1895	

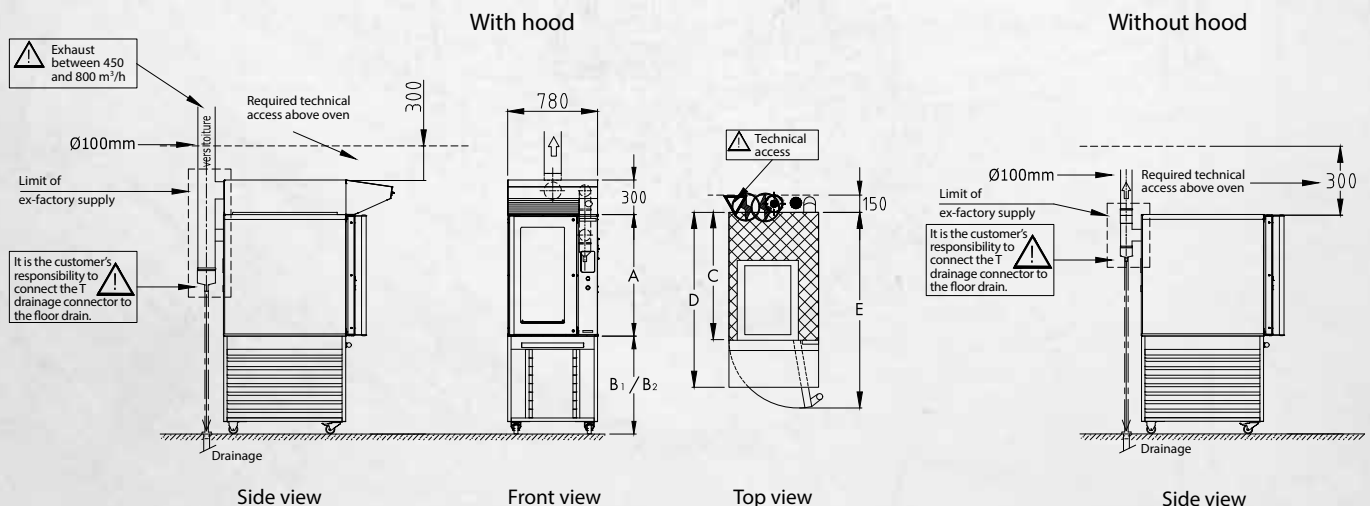

• : Standard

o : Free option

€ : Option with extra charge

- : Unavailable

- € : Reduction

KRYSTAL+ TRAY CONVECTION OVENS

Technical data

	KRYSTAL+ 46.4	KRYSTAL+ 46.9	KRYSTAL+ 46.10	KRYSTAL+ 48.4	KRYSTAL+ 48.9	KRYSTAL+ 48.10
Baking supports (mm)						
Tray dimensions	400 x 600			400 x 800		
Number of levels	4	9	10	4	9	10
Distance between levels	95	100	90	95	100	90
Area (m²)						
Floor area	0.9			1.0		
Baking area	0.96	2.16	2.4	1.28	2.88	3.2
Connection capacity (kW)						
Of the oven (if standard power)	10.3	18.6	18.6	10.3	18.6	18.6
Of the oven (if reduced power)	6.9	12.5	12.5	6.9	12.5	12.5
Of the hood	0.2			0.2		
Of the proofbox	1.0			1.0		
Electrical characteristics (A)						
Electrical protection (3N~400 V)	18	32	32	18	32	32
Electrical protection (3~230 V)	32	63	63	32	63	63
Weight (kg)						
Of the oven	145	230	230	160	250	235
Of the stand with tray storage, without castors	30			30		
Of the stand with tray storage and castors	33			33		
Of the proofbox without a drawer or castors	95			95		
Of the proofbox with a drawer and castors	103			103		