

## Mychef Bakershop 4 460x330



### TECHNICAL SPECIFICATIONS

Capacity	4 x 460x330
Distance between guides	75 mm
Rations per day	80-180
Maximum temperature	260 °C
Dimensions (WxDxH)	620x690x522
Weight	53 Kg
Packaging dimensions (WxDxH)	830x770x900
Gross weight	65 Kg
Power	3.6 kW
Voltage	230/L+N/50-60
Water	R 3/4"
Drainage	No drainage
Water pressure	150 - 400 kPa

### GENERAL SPECIFICATIONS

- LCD control panel
- Regulation of humidity, temperature, time and speed
- 40 programs with 3 cooking phases each
- 8 quick access memories
- Convection cooking with humidity contribution from 30°C to 260°C
- High thermal inertia camera
- Fan stop when door is opened
- Two fan speeds and reverse rotation
- LED camera illumination
- Low emission double glass hinged door
- Door opening positioner
- EN guides
- Door and frame rainwater collection system with drainage

### OPTIONALS

- Water connection kit to carafe

### ACCESSORIES

- Special trays for each baking
- Washing shower
- Condensation hood
- Detergent DA21
- Support table
- WiFi connection
- MyCloud remote control
- Compatible with Google Home Voice Control

## INSTALLATION DETAILS

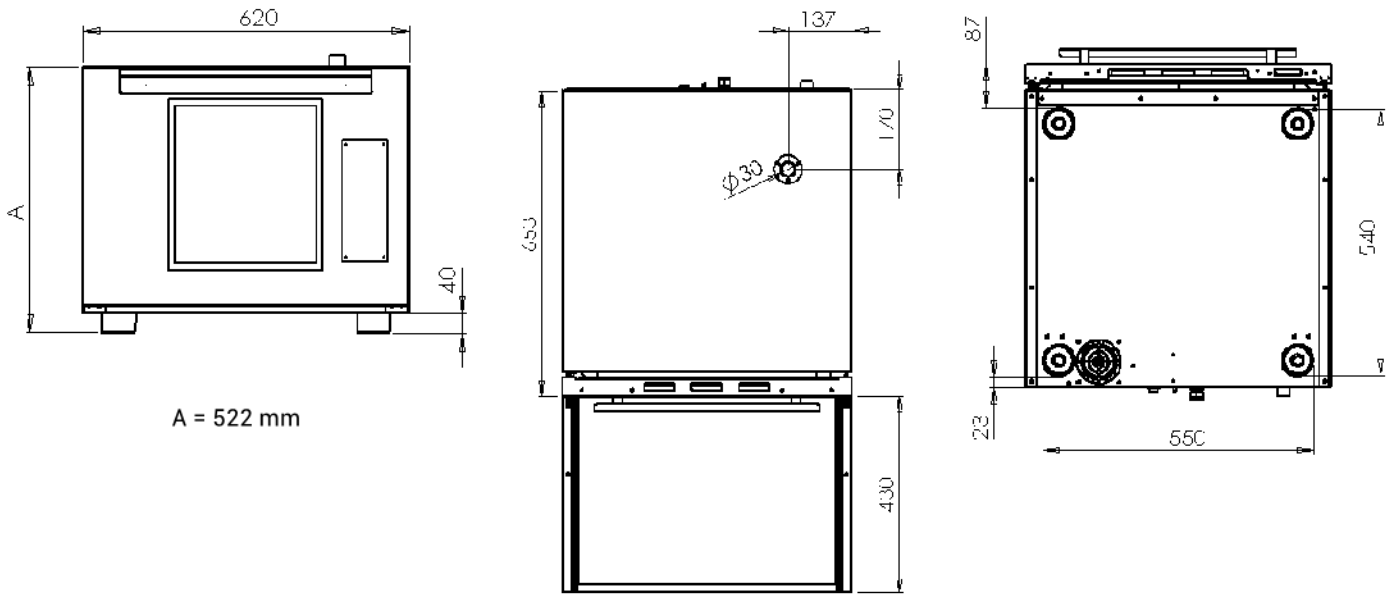

A = 522 mm

## SAFETY DISTANCES

Sides = 50 mm

Rear = 100 mm

Upper = 500 mm

Heat sources = 1000 mm

It must be completely level

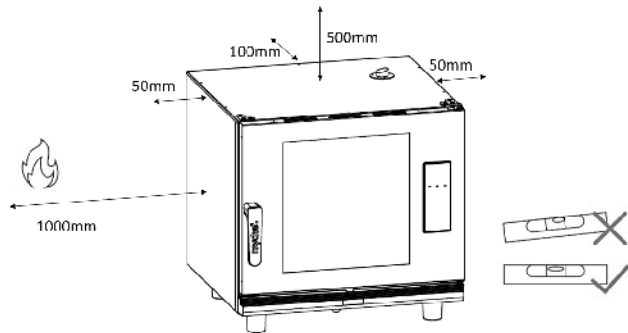

## POWER CONNECTION

230/L+N/50-60

Power (kW)	Current (A)
3,6	14,3

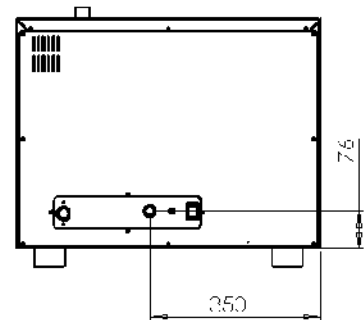

## WATER CONNECTION

A Connection 3/4" treated water

## QUALITY OF WATER

Temperature < 30°C

Pressure 150 to 400 kPa dynamic flow

Hardness between 3° and 6° FH

PH between 6.5 and 8.5

Chlorides below 30 ppm

Use of water softener and filter required

